

ETT 29 SNV

SPRINTER AERIAL UNIT "TECH PACKAGE" VAN MOUNTED AERIAL LIFT



INNOVATIVE DESIGN

The Sprinter Aerial unit is a specialty unit designed with the telecommunications market in mind. With an aerial that has a working height of 35 feet, this unit offers all of the benefits of a quality aerial unit mounted on the heavier Sprinter van chassis. One of the many innovative features of this unit is that the inside of the van is designed with a bridge frame to provide increased storage capacity and greater accessibility. Standard features include an hydraulic platform leveling, an inner boom actuated by a cylinder extension system, and internally mounted holding valves that lock cylinders in place in the event of a hydraulic failure. This unit offers a wide variety of options from adding an electric tool circuit to an oversized bucket to satisfy every equipment need.



DEPEND ON IT.™



ETT29SNV

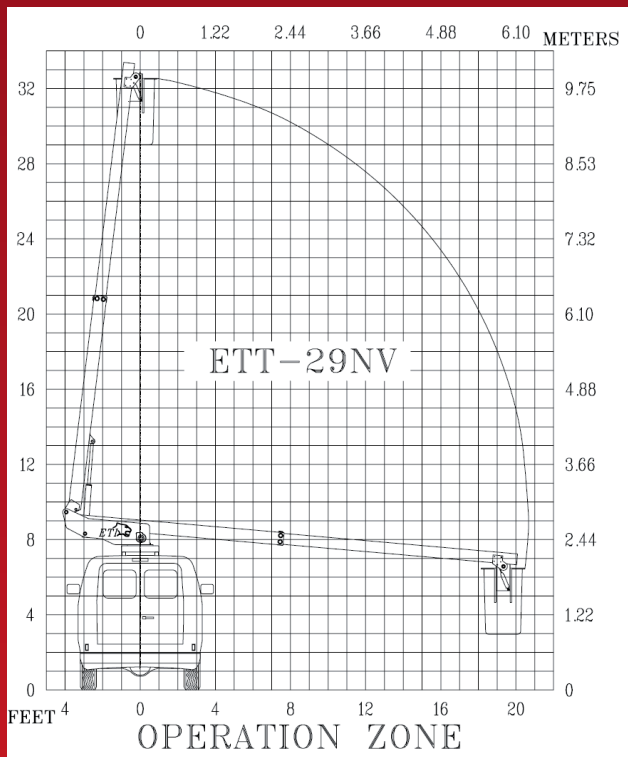

EQUIPMENT TECHNOLOGY LLC IS A FULL SERVICE SOLUTION PROVIDER OF THE HIGHEST QUALITY DESIGN, MANUFACTURING, AND POST SALE SERVICE.

EQUIPMENT TECHNOLOGY LLC

341 NW 122nd
 Oklahoma City, OK 73114
 Toll-Free: 1-888-748-3841 • Fax: 1-405-755-6829
etiequipment.com

GENERAL SPECIFICATIONS*

Bridge mount pedestal for van*
 Height to bottom of bucket 30 ft. - 0 in.
 Working height 35 ft. - 0 in.
 Side reach 20 ft. - 9 in.
 Stow height 10 ft. - 5 in.
 Rated bucket capacity 350 lbs.

MINIMUM VEHICLE SPECIFICATIONS

GVWR 11,030 lbs
 GAWR (front) 4410 lbs
 GAWR (rear) 7720 lbs. (DRW)
 Wheelbase 144.3 in.
 Engine Diesel 3.01 CRD V6

HYDRAULIC SYSTEM

OPERATING PRESSURE (MIN) 2,000 PSI.
 OPERATING VOLUME (MIN) 2.5 GPM

STANDARD UNIT FEATURES

- Van mounted units utilize a bridge frame in lieu of pedestal providing increased storage capacity and greater accessibility to van interior.
- Shear ball rotation gear driven by internal drive gear box.
- All pins turn on replaceable bushings.
- The gear box has an extended shaft for manual rotation.
- Inner boom is actuated by a cylinder extension system.
- Adjustable wear pads.
- Internally mounted holding valves (integral part of cylinder) lock cylinders in place in event of hydraulic failure.
- Lower controls accessible from the ground.
- Hydraulic platform leveling
- Spicer bucket

OPTIONS

- Emergency hydraulic power system
- Start/stop system
- Bucket cover
- Airline to bucket
- Electric tool circuit
- Oversize bucket (24" x 30" x 42")
- Inverter
- LED Interior lighting
- Interior shelving
- Generator

Hydraulic power options

- Fan belt pump
- DC Power
- Generator



Specifications are subject to change without notice
 Note (*): All specifications are based on 40" frame height